

UAV / drone magnetometer survey kit

MAGDRONE R4 3.0



Applications

- Survey & Surveillance
- Mine exploration / tracking / monitoring at flexible heights
- UXO detection on unreachable, flooded or mined areas

Features

- Dismountable system with 5 Fluxgate sensors
- Attachable to any UAV with 1.5+ kg payload
- **Made for DJI M300**
- 8 GB internal memory
- 200 Hz recording rate
- Data loss prevention
- WLAN interface
- Data processing tool

The MagDrone R4 is an ultra light weight magnetometer survey kit with 5 triaxial Fluxgates to be attached to any UAV with a **1,500 g payload**. Its dismountable sensor tube allows for sensor spacing of either 25cm or 50cm providing a 2.5m swath width.

With 200Hz sampling rate the R4 can easily filter out noise from infrastructure, net frequencies or UAV motors. Hence, it can be directly installed on UAV's landing gear for a very compact setup.

The MagDrone R4 can be used for i.e. magnetic cartographies, mine exploration, area scanning for bombs and ammunition (UXO), preventive check and surveillance of areas and camps against intrusion.

The MagDrone Data Tool identifies flown tracks, cut, filter, compensate the raw data, generates a preview and exports into various formats to further process the recorded values, i.e. with our MAGNETO®.

R4: ALL UNIQUE SELLING POINTS AT HAND

Your benefits with our solution

- ✓ **Universal usage**
 - UXO Search
 - Exploration
 - Surveillance
- ✓ **Ideal for DJI M300/M350**

With 1,500g, the R4 gets on board any professional UAV easily, but especially the DJI M300/M350!
- ✓ **Straight interface**

Access the R4 via WLAN for configuration or start/stop triggers.
- ✓ **Most simple installation**

Take 4 cable ties and strap it on your UAV landing gear.
- ✓ **1-button operation**

You can't go wrong – the R4 has only one button to make operation as simple as possible!
- ✓ **Noise cancellation**

Due to a high sampling rate, UAV motor noise is accepted, detected and can be filtered out during raw data export.
- ✓ **Powerful DataTool**

The free MagDrone DataTool lets you delete tracks, compensate, filter, ... and allows various exports!

Most frequent questions

- **What can it detect?**

The magnetometers detect everything ferrous (iron) – but i.e. not Aluminum or Gold as they are conductive only.
- **Does it work over water?**

Yes. Water doesn't affect sensor operation or damping the magnetic field strength (to be detected).
- **How deep can it sense?**

It depends. The R4 sees a harvester machine from 40m distance; but a hand grenade from only a few centimeters.
- **Sensitivity of the sensors**

The sensitivity of the installed FGM3D/75 is 0.13V/μT, the resolution is better than 150pT.
- **Ideal flight height?**

For compact objects: as close as possible – 50cm above ground. Can be dozen of meters for soil structures.
- **Interference from UAV**

Constant noise (motors) is ok and is filtered out, but don't use a camera gimbal with the R4.

R4: TECHNICAL

General Technical Data

Power Supply	12-32 V
Operating Temperature	-20°C to +50°C
Weight	1,500 g
Overall power consumption	10 W
Sensor tube dimensions (L x D)	2,074 x 29 mm

FGM3D/75 Fluxgate

Number and orientation of sensors	5 sensors, laid horizontal, parallel
Specified measurement range	±75,000 nT (other ranges on request)
Number of sensor axis	3
Distance between sensors	500 mm
Noise level @1Hz [pT/ (Hz)]	10 pT < all sensors M1-M5 < 20 pT

Datlogger

Power	50 mA
Sensor input	Hard wired, 50cm sensor cable
User Interface	Start/Stop button; Webserver
Survey mode	Continuous recording while airborne
Sampling rate	200 Hz (higher rates available on request)
Internal memory	8 GB (approx. 120h recording)
Datlogger dimensions (W x D x H)	264,5 x 104,5 x 80 mm

Data Processing

MagDrone DataTool (included)	Raw data filtering, track & flight direction detection, noise compensation, MagBase or GPS referencing, export, preview
MAGNETO [®] Software	Data interpretation, visualization, object calculation, etc.
Live output	Via Ethernet interface

GPS Add-on

EMLID M2 / RS2	Interface for EMLID M2 multiband RTK GPS with optional EMLID RS2 base station
----------------	---

R4: DATALOGGER INSTALLATION

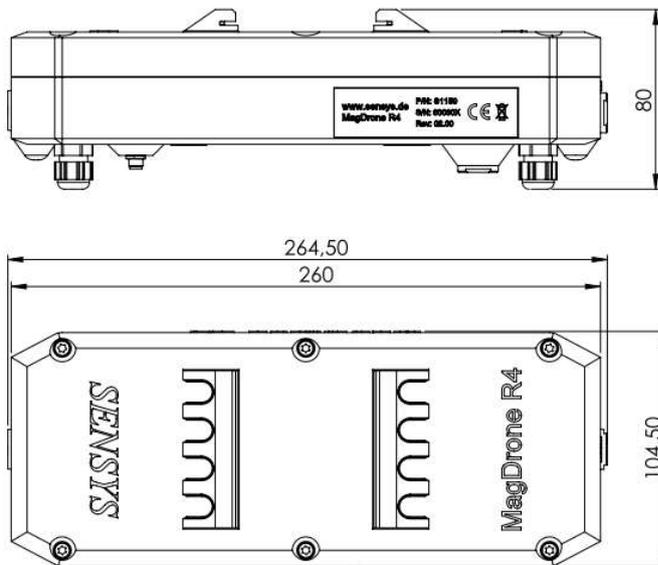

R4: SENSOR BAR DIMENSIONS

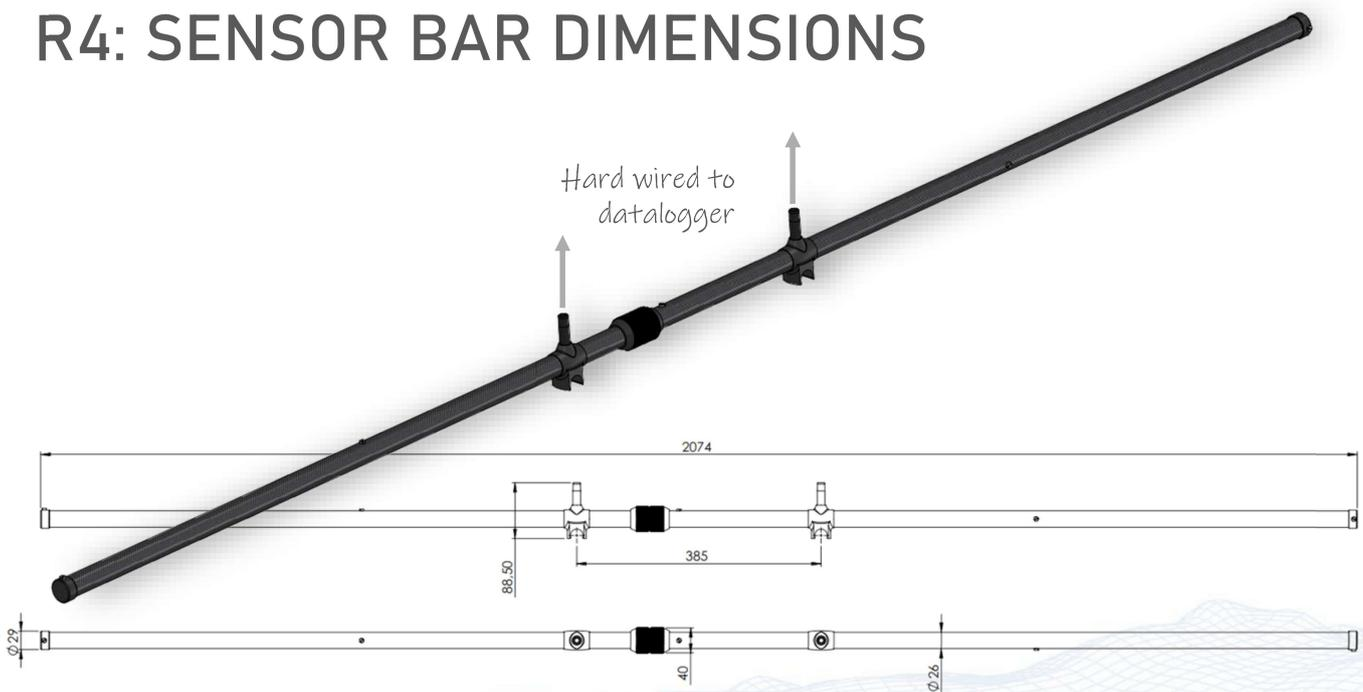

R4: STANDARD PACKAGE AND OPTIONS

Standard package

MagDrone R4 Survey kit with 5 triaxial Fluxgates

Ask for price!

- 5x FGM3D/75 Non-Dual Use at 50 cm distance
- CFRP sensor tube
- Data logger with internal storage
- Mounting plate and screws for DJI M300
- USB memory clip with MagDrone DataTool
- Manual / Certificate
- Transport hard case

Options

MAGNETO[®] Software

5,410.- €

- For data interpretation, visualization, object calculation, etc.

EMLID M2 + RS2 RTK DGPS Rover and base package

Ask for price!

or

SPH SkyHub Controller for DJI M300

Ask for price!

- To overrule DJI controls for low altitude flights and terrain following mode, output GPS stream

R4: IN OPERATION WITH OUR CLIENTS



MagDrone R4 in Bavaria - 120 ha in 4 days

The Bavarian State Department of Monuments and Sites, Archaeological Prospection, Munich, Germany undertook a Large-scale UAV magnetometry on a former World War II airfield at Ganacker (Lower Bavaria, Germany), published at DGG's 2022 conference in Munich.

“The aim of the study was to test the capabilities of SENSYS MagDrone R4 for Archaeological Prospection. [...] Due to the quite flat terrain of the test site, the R4 could be operated at a fixed flight height of just one metre above the surface. A radar sensor controlled the constant flight height of the UAV. The 200 Hz sampling rate of the FGM3D/75 sensors allows easy filtering of interference generated by the UAV and external disturbances like power lines or infrastructure. Magnetograms with a spatial resolution of up to 0.20 m per pixel were produced using the R4 data. To calculate the intensity of the anomalies, a 25 m running median was applied to the total intensity raw data. Since three-axis fluxgates are based on the same physical principles as widely used fluxgate gradiometers (Gavazzi et al., 2021), this simplifies the interpretation of the R4 borne magnetograms. For the archaeological interpretation, multi-temporary historical aerial photographs and several recent digital orthophotos were used.”

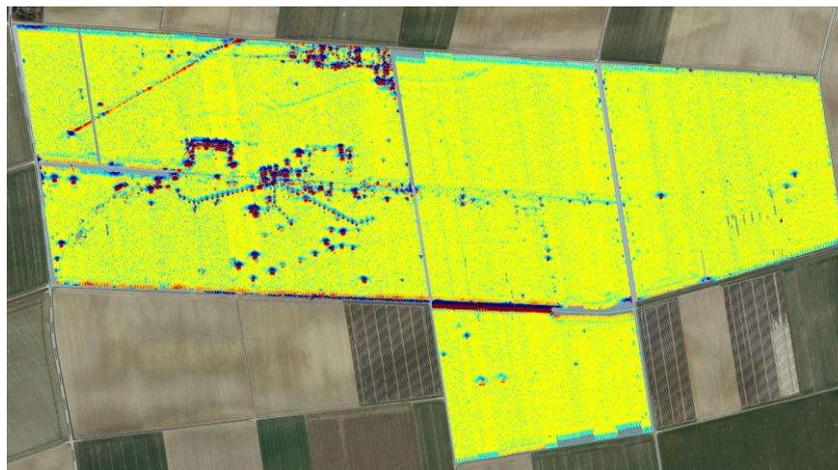

Conclusion:

“The R4 offers an outstanding survey progress that cannot even be reached by common vehicle-moved multi-sensor arrays. Thus, efficient UAV magnetometry provides the possibility of mapping the subsurface of huge areas during short time.”

By: Andreas Stele, Roland Linck, Markus Schikorra